

INSTRUCTION MANUAL

FOR THE

ISOTRON 160C

ISOTRON 225

MANUFACTURED BY

**BILAL COMPANY
137 MANCHESTER DR.
FLORISSANT, CO. 80816
PH: 719/687-0650**

TABLE OF CONTENTS

ASSEMBLY INSTRUCTIONS	2
TUNING	4
ASSEMBLY DIAGRAMS	5, 6, 7, 8, 9
WARRANTY	10
FINDING THE RESONANT POINT	11
TRIMMING THE COIL	13
COMPENSATION FOR VARIATION IN LOCATION	14
SIDE TOWER MOUNTING	16
GROUNDING	16
THE USE OF A TUNER	17
POWER RATING	18
SINGLE FEEDLINE OPERATION	19
PERFORMANCE	20

INTRODUCTION

The Isotron 160C will be assembled from the bottom up. You will need a metal mast to support the antenna during assembly. A temporary mast can be used if you are going to relocate the antenna.

The Assembly instructions will refer to diagrams 1 - 5.

PARTS LIST (See Fig. 1-5 for identification)

1. TOP PLATE #11
2. BOTTOM PLATE #1
3. BOTTOM SUPPORT #2 (4 HOLES, 7/8" OD, NON-METALLIC).
4. MIDDLE SUPPORT #6 (3 HOLES).
5. TOP SUPPORT #13 (4 HOLES).
6. COIL #4 WITH 1/4" CROSSBAR.
7. BOTTOM COIL SUPPORT ROD #3, 8 1/2" X 1/4" SOLID ROD.
8. TOP COIL SUPPORT RODS #5, TWO 30" X 1/4" SOLID ROD.
9. TUNING ROD #14, 36" X 1/4" SOLID ROD, NO THREADS.
10. GROUNDING WIRE #15.
11. TUNING ROD BRACKETS (TWO) #9 AND #12.
12. 1/4" COUPLING NUT.
13. 1/4" SS NUTS - QUANTITY 15. 1/4" X 1/2" SS BOLT - QTY 2.
14. 1/4" SS FLAT WASHER. U-BOLT ASSEMBLIES - QTY 3

ASSEMBLY

1. Attach BOTTOM SUPPORT #2 to BOTTOM PLATE #1. Use one 1/4" x 1 1/2" bolt with a GROUNDING WIRE #15 and nut. Use the holes that are closest to the mast, do not tighten at this time. See FIG. 1. NOTE: PLATE #1 has the SO-239 Connector mounted on it.
2. Attach COIL #4 to BOTTOM COIL ROD #3. Each end of #3 should have a nut threaded to the end of the threads. The end with the shorter threads is screwed into the COIL #4 bottom. The nut is snugged to the coil to secure it. See Fig. 1 & 2.
3. Mount the COIL #4 to the BOTTOM PLATE #1/BOTTOM SUPPORT #2 by inserting BOTTOM COIL ROD #3 into the hole farthest from the mast. Use a second nut to secure. Now you can snug up both nuts on the BOTTOM SUPPORT #2. See Fig. 1.
4. Put a stop nut on each end of the COIL CROSS BAR. Insert the COIL CROSS BAR into the side holes and secure with a second nut. See FIG. 2. NOTE: There may be some downward tension on the bar.

5. Attach the wire pigtail from the SO-239 Connector and the wire pigtail from the bottom of COIL #4 to the 8/32 stud at the bottom of the coil. Remove one nut, put the solder lugs on and replace the nut and secure. See Fig. 1 and 5.
6. The TOP COIL ROD #5 comes in two sections. See page 7 fig. 3. Each section is 30 inches long. Screw a regular nut on one end of #5 on each section. Screw the coupling nut to the same end of each section so each section of #5 is about 1/2 way into the coupling nut. Tighten the regular nuts *against the coupling nut on each side.*
Put one nut on one end of the TOP COIL ROD #5. Put this threaded end through the wire eye at the top of the COIL. Attach a second nut, then screw the TOP COIL ROD #5 into the COIL. With the threads most of the way into the coil, tighten the nut against the coil, then tight the nut above the wire eye. See Fig. 1 and 3.
7. Slide the MIDDLE SUPPORT #6 on to the TOP COIL ROD #5. Use the single hole at the end of the support. This support will be at 1" above the adjacent nut on the COIL.
8. Mount two U-BOLTS on the mast at 20 1/2" apart starting at the bottom of the antenna. See Fig. 6
9. Mount SUPPORTS #2 and #6 on the U-bolt. Be sure they are parallel, then secure with a second nut from the U-BOLT package.
10. Slide TUNING ROD BRACKET #9 onto TOP COIL ROD #5, leave it loose. See Fig. 3.
11. Attach the TOP PLATE #11 to TOP SUPPORT #13. Use a 1/4" x 1 1/2" Bolt with a nut, but do not secure. See Fig. 3.
12. Mount a third U-BOLT to the mast at 76" from the bottom one. See Fig. 6.
13. Slide the TOP COIL ROD #5 through the U-JOINT #10. If needed you can loosen the set screw, but re-tighten once everything is in place. See Fig. 3
14. Slide the second TUNING ROD BRACKET #12 on to the TOP COIL ROD #5. See Fig. 3.
15. Thread a 1/4" nut all the way down on the top of TOP COIL SUPPORT #5. Then add a flat washer from the hardware packet, then slide into the hole attaching the TOP SUPPORT #13 and TOP PLATE #11. Secure with a second nut, then secure the 1 1/2" Bolt previously installed. See. Fig. 3.

16. Mount the TOP SUPPORT #13 on to the top U-BOLT and secure with a second set of nuts from the U-BOLT Packet.
17. Slide the TUNING ROD #14 through the two TUNING ROD BRACKETS #9 and #12. #12 will always be positioned at the top of rod #5. # 9 will always stay with the bottom of the TUNING ROD #14.
TUNE UP
1. The Isotron 160C should be mounted as high and in the clear as possible on a metal mast. See Fig. 6 on page 9b for the proper installation of the U-BOLT Assemblies.
2. 50 ohm coax should be connected to the SO-239 Connector on the antenna. The coax should either be secured to the mast with tape or stand-offs. A neat run with no excess should go to the radio.
3. Lengths of coax that are an exact 1/4 wavelength should be avoided. This length would have the velocity factor considered for your type of coax. This is only for the first 1/4 wavelength. Adding a few feet of coax to avoid this length is fine.
4. No tuning devices should be in the line for the initial tune up. These can be used later if desired.
5. Maximum resonant frequency will be with the TUNING ROD #14 in the lowest position or removed.
6. To decrease the resonant frequency, raise the TUNING ROD #14 according to what you want. Secure the Brackets #9 and #12 keeping them positioned properly. Refer to step 17.
7. Start at low power and graph your SWR across the 160M band. Locate the minimum SWR. This is your resonant point. Please read over the section on "FINDING THE RESONANT POINT".
8. For frequencies higher than 2.0 Mhz see the section on "TRIMMING THE COIL".
9. If the minimum SWR is not low enough, then refer to the topic "COMPENSATION FOR VARIATION IN LOCATION" for the minor adjustment.

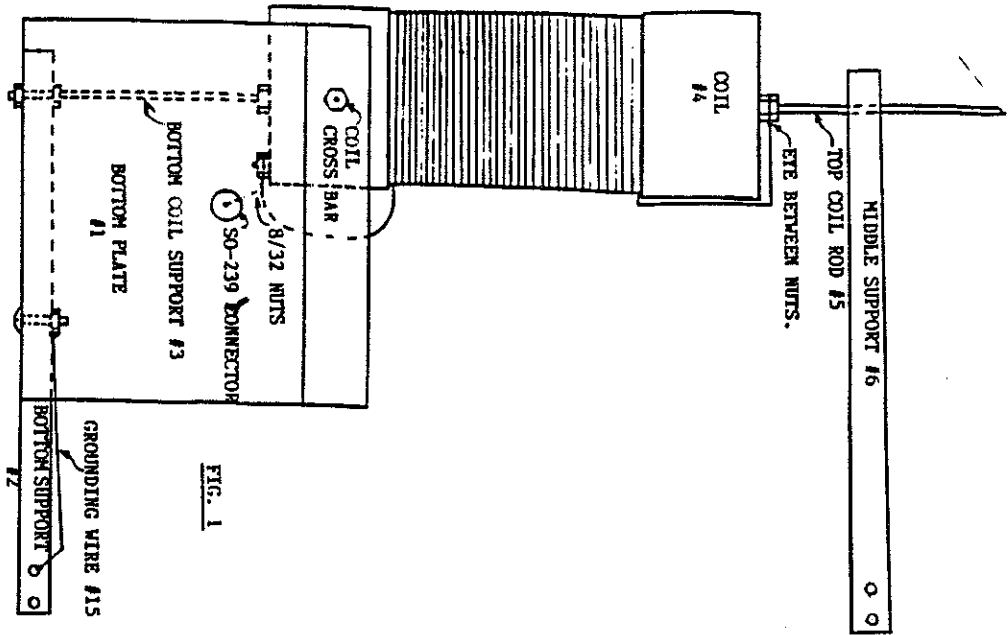

FIG. 1

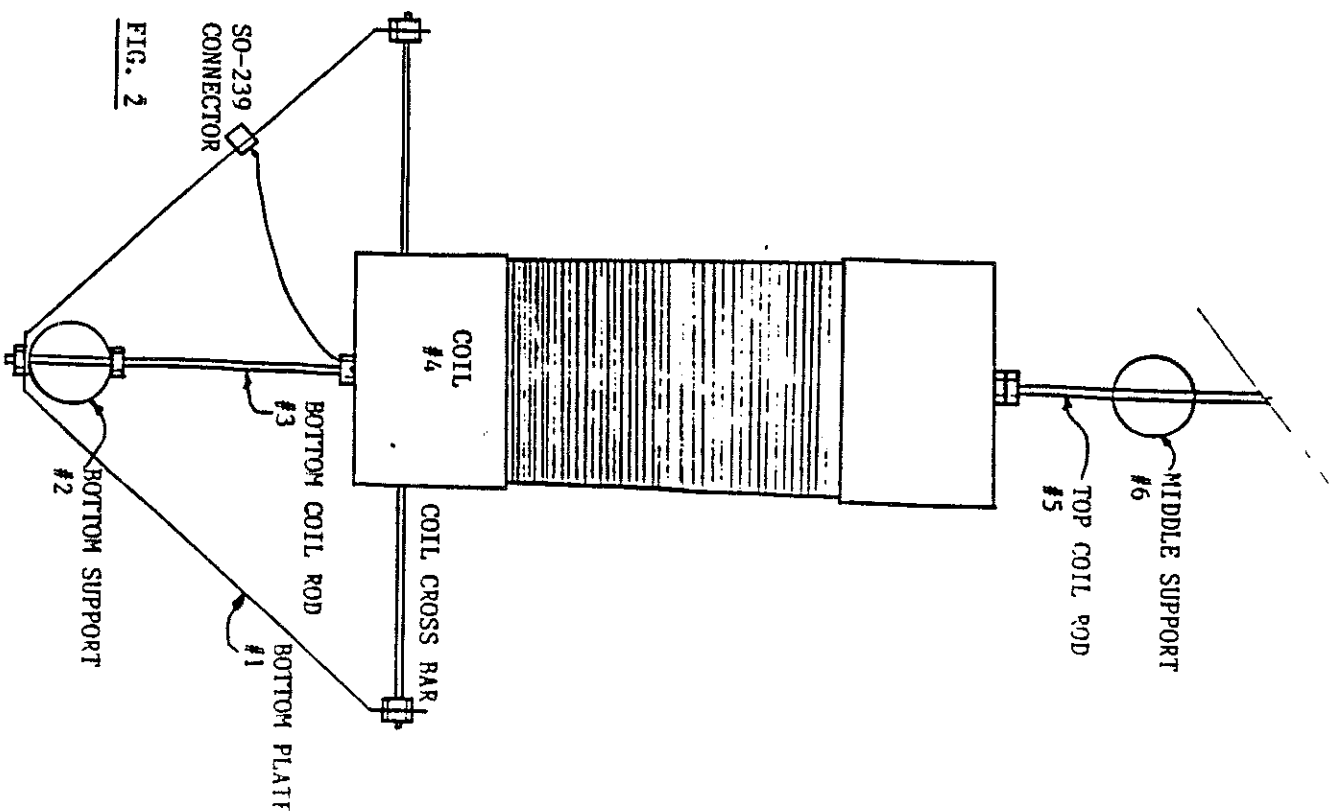

FIG. 2

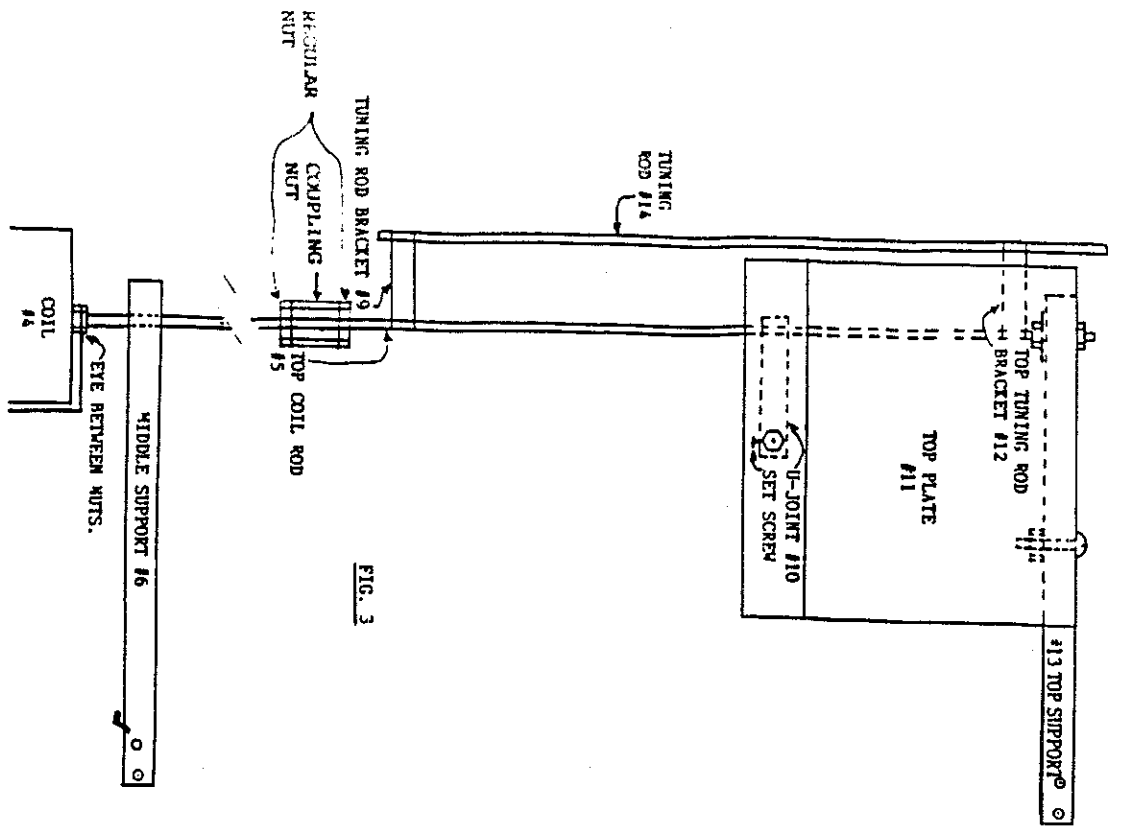

FIG. 3

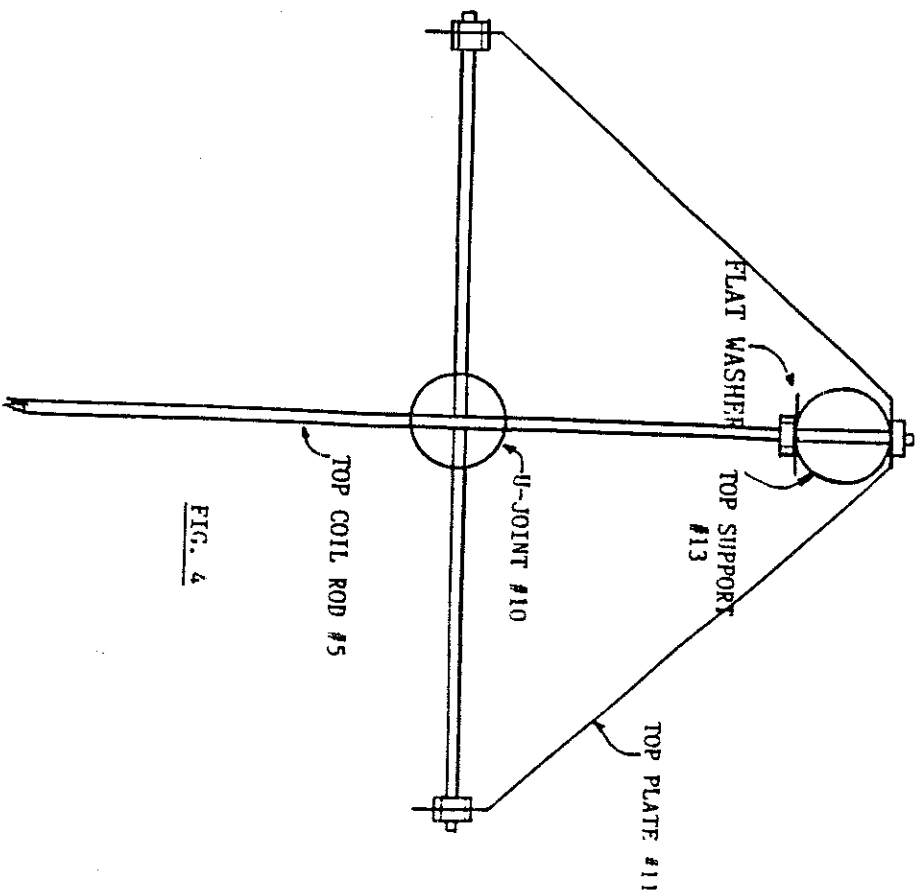
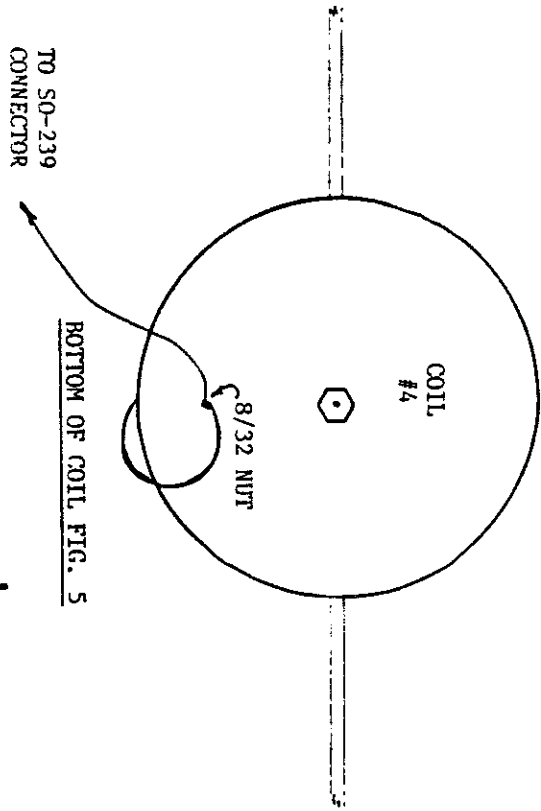

FIG. 4



BOTTOM OF COIL FIG. 5

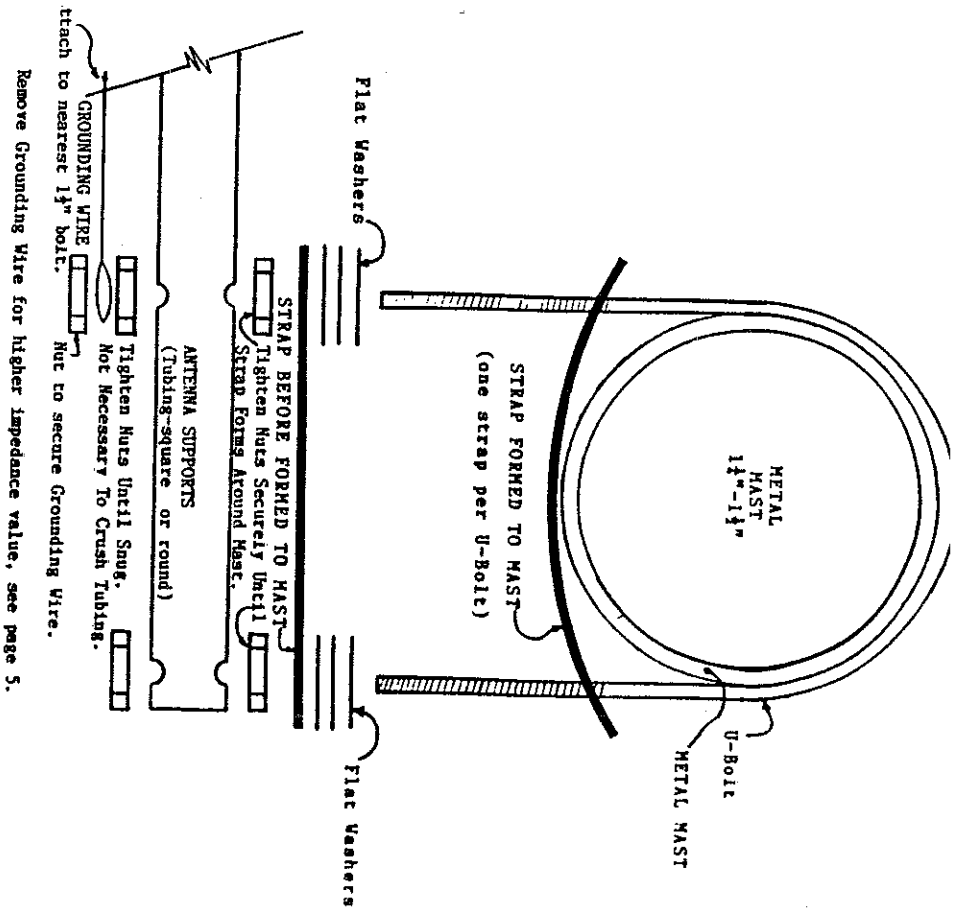

FIG. 6

This wire may be cut to splice a capacitor in place for impedance values between the two values. (100 pf or less for the 80 or 40, 1,000 pf or less for the 160)

Remove Grounding Wire for higher impedance value, see page 5.

FINDING THE RESONANT POINT

1. Locating the resonant point is the major part of the tune up. The following steps is a reliable technique for locating the resonant point.
2. IF YOUR SWR IS OVER 3:1, IT IS A RESONANT POINT ADJUSTMENT THAT NEEDS TO BE MADE.
3. You will need a SWR meter. You will also need to hear the receiver from the antenna location.
4. Connect the antenna to your transceiver by means of a suitable length of coax. NEAT RUNS AND INSTALLATIONS ARE VERY IMPORTANT.
5. Tune your receiver to the frequency desired.
6. Listen to the Noise/Signal at this frequency.
7. Bring your hand toward the top plate of the antenna.
8. Carefully listen. If the Noise increases at some point while your hand is approaching the Top Plate, then the resonant point is higher than the frequency you are set at.
9. You will need to make the necessary adjustments to lower the resonant point of the antenna. (Rotating or adding hardware.)
10. If the Noise decreases only while bringing your hand toward the Top Plate, then the antenna is resonant at a lower frequency than the receiver is tuned.
11. If the antenna resonant point is low, it is best to start at the lowest frequency available to you. Check it again with your hand. This technique for determining the resonance is very reliable. It is not necessary to spend a lot of time guessing where the antenna is resonant. Continue this procedure through the following steps as a reliable resonant point check.

12. If the resonant point is low, it will be necessary to remove all tuning hardware to bring the resonant point to maximum. It is possible for your environment to make the antenna resonate below the designed band.
13. If the test shows the antenna is resonant lower than you desire or below the band, then tune your receiver to the lowest frequency available to you. Check the SWR as in the next step.
14. SWR should be checked at the lowest power that the meter will read. The sensitivity control should be all the way up and the meter calibrated by the gain on the exciter.
15. Note the SWR at the lowest frequency. Then move up 25 khz and check the SWR again. Continue to do this until you can see a pattern.
16. If the SWR increases as you move up frequency, then the resonant point is below the band or minimum frequency. Trimming the coil may be necessary. (See page 11 for 160 - 40.)
17. The object is to locate a minimum SWR by graphing as described in step 15.
18. If you have a general coverage receiver you can listen at a lower frequency and check the antenna with your hand as described.
19. Once your resonant point is located in your operating area, your SWR will make a noticeable dip (below 3:1). Unless your environment interaction is very strong, this normally produces a low and acceptable SWR.
20. If you are using a Noise Bridge, it should be located near the antenna for tune up.
21. Impedance may be adjusted if necessary after completion with the resonant point. This is described on pages 14 through 15.

TRIMMING THE COIL

For specific frequencies such as for MARS, CAP, FAA and so on where frequencies near, but not in the amateur band are required, coil trimming may be done to reach those frequencies. In cases of extreme environment interaction, trimming may be necessary for proper resonant point.

Before trimming the coil, the antenna must either be properly operating at some point on the band being used, or you have confirmed the resonant point is lower than where your operating. **DO NOT TRIM THE COIL PRIOR TO THIS.**

Remove all the tuning hardware and take note of where the resonant point is. Trimming will be from this point, therefore the tuning hardware could be used for lowering the resonant point to where desired.

1. Remove the Top Coil Support.
2. Tape the coil securely so the windings will unravel.
3. Clip the eye on the top lead of the coil.
4. Slide the wire back through the two holes in the coil form.
5. REMOVE 1/2 TURN AT A TIME! Slip the wire back through the two holes from the opposite direction. Looking through the hole as the wire comes to you will help line it up.
6. Reconnect the wire to its original position and trim the excess.
7. Check your resonant point. If needed repeat the procedure as many times as necessary in 1/2 turn increments.

COMPENSATION FOR VARIATION IN LOCATION

The antenna-to-ground capacitance of your ISOTRON antenna depends on its location with respect to other objects and to the ground itself, and how and where it is mounted. Antenna-to-ground capacitance affects resonant frequency and feed-point impedance of your antenna.

For example, if the ISOTRON is mounted on a tower, somewhere near the middle, its resonant frequency and impedance value will be lower than if the antenna is mounted in the clear. By insulating the antenna from the tower, you can increase its feedpoint impedance and raise its resonant frequency. Different locations on the tower will produce different values, and it may be necessary to compensate differences by tuning your ISOTRON. If the feedpoint impedance and resonant frequency become higher than desired, then it is possible to decrease them by connecting a capacitor of about 100pf or less between the antenna and the tower (see Pg. 9b, Fig. 6). Another words the lowest impedance would be directly grounding the antenna to the mast. A point in between can be obtained by the use of a capacitor as described.

This technique will apply on most mountings where the feedline is longer than 1/8 wavelength. If the feedline is shorter, then the impedance value is determined by the ground of the radio and cannot be varied.

It is important to know what the value of the impedance will be at resonance, and what the resonant frequency of the antenna is. An impedance bridge (Noise Bridge) is a very good way to make these measurements, and can be a valuable investment for the radio operator. A Noise Bridge is quite inexpensive, and enables you to make the measurement quickly, simply and accurately.

If a Bridge is not available, then a little guess work will tell the story. Once you located the resonant point and put it where you want, your SWR should be no higher than 3:1 at a low power reading. The antenna should be grounded when determining resonant point. Release the grounding wire (12). Check the SWR. The resonant point may move up a little and will have to be relocated.

Attic and top-of-building mounting where your ISOTRON cannot be easily grounded, could produce a feedpoint impedance of as much as 200 ohms. It is desirable to ground your antenna to a good earth ground, but if this is not possible, then the next best thing is to use the ground in your electrical system. This is attached to your outlets where the third prong would insert on some appliances. The ground wire should be attached to the bottom of the mast only where the antennas are mounted. Please note that the shield of the coax is not considered to be the same ground as the grounded components of the antenna, such as mast or bottom plate.

The diagram on page 14 shows how to insulate your antenna from ground if necessary and how to connect the mica or ceramic capacitor for values in between.

One factor to consider is the environment interaction when transmitting at various power levels. The instructions on page 7 call for tuning at a minimum power level. In some very tight or highly conductive surroundings (metal sidings, machinery, etc.) will show up as an increase in SWR from the low power to the high power setting. This can be compensated for by relocating the antenna. If this is not practical a tuner can clean this up. (See the sheet on USE OF A TUNER)

SIDE TOWER MOUNTING

The antennas should be offset from the tower. This can easily be done with a 5 or 10 foot mast mounted across the legs of the tower. The Isotrons can be mounted horizontally on the mast. A light nylon cord could be attached to the mast an back to the tower at a 30 to 45 degree angle to keep the mast from drooping.

GROUNDING

There is much confusion about grounding antennas. The Isotrons do not use a ground for performance. Grounding offers a change in impedance value as well as protection against static discharge.

The ONLY way to ground the Isotrons is by connecting the ground wire to the bottom of the mast the antenna is mounted on.

NEVER run a ground wire up to the antenna. The wire will interact with the feedline and drastically change the tuning. Avoid running ground wires parallel to the feedline if possible.

THE USE OF A TUNER

The instructions provided basically discourage the use of a Tuner. This is for the purpose of initially tuning up the antenna. However there are times when a tuner has its place.

With the increasing popularity of solid state transmitters a tuner is almost a must. Back in the days when tube finals were used the manufactures automatically provided the tuner. Since the solid state circuits have become popular, they have left the tuners out. This makes it a must for an antenna system to be very critically tuned so the exciter will not cut back its power. In many cases this is very impractical and the use of a tuner can be a good asset to your set up.

In tight locations or locations not favorable for an antenna installation, the impedance of the antenna may not adjust to the 50 ohms needed. An installation indoors with a very short feedline may keep the impedance lower than 50 ohms. The recommended adjustments may have little affect due to the short feedline. At the lowest the antenna will exhibit a 20 ohm impedance, giving a SWR of around 3:1. Please keep in mind that if your SWR is over 3:1 the problem is your resonant point, not impedance value. This can be corrected by following the instructions on resonant point.

If you find isolating the antenna from ground does little to raise the impedance due to your location, then the tuner can be used to match the exciter to the antenna. This will not sacrifice performance if done correctly.

Expanding bandwidth is another asset of the tuner. To avoid retuning the antenna for different parts of the band a tuner can be used to flatten the line and make it acceptable to the exciter.

In conclusion, tuners can be used if not abused in your installation. Under a conventional installation the Isotron will tune up directly, but many operators have to operate in less than ideal circumstances. The Isotron was intended for this challenge and we will be willing to help you with it.

POWER RATING

The power rating defined in the catalogue is INPUT POWER. This is how many exciters are rated. However, some exciters or amplifiers are rated in OUTPUT POWER.

The Isotrons are intended to handle outdoors 1,000 watts PEP or 500 watts CW into the antenna. Indoors the rating is 500 watts PEP or 250 watts CW into the antenna.

YOU SHOULD MONITOR YOUR SWR AT ALL TIMES WHEN USING HIGH POWER.

**IF THE SWR IS UNSTABLE OR SLOWLY INCREASES WHILE TRANSMITTING,
CUT BACK YOUR POWER IMMEDIATELY UNTIL IT STABILIZES!**

SINGLE FEEDLINE OPERATION

The Isotrons have been designed so they can be mounted back to back. As many as three can be mounted this way around a mast at the same height.

Electrically the antennas can be fed with one feedline by simply connecting them in parallel. Three antennas of any band you desire work well on one feedline. There is no limit to how many you can put on a single coax. However, the more you connect over three the more complicated the match becomes. An electrical diagram is shown below.

With antennas mounted back to back, a coaxial "T" is connected to the antenna of the highest band. This is done by either the male side of the "T" or by a short jumper from the female side. The remaining connection will jumper over to the next highest frequency antenna. If there is a third antenna, then the procedure is repeated again.

Tune up is the same for the resonant point as in the individual antennas.

Impedance value becomes the average of all of them. Therefore if you isolate one antenna from ground, you must isolate all of them. What you do with one antenna for impedance you do with all of them. You can see if you have over three it can get quite complex and the aid of a Noise Bridge will be a big help.

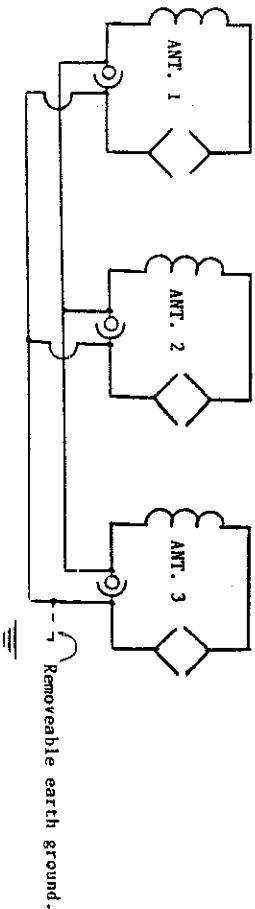

CONFIGURATION OF THREE ANTENNAS ON ONE FEEDLINE CONNECTED IN PARALLEL.

PERFORMANCE

What makes the Isotron Antennas perform?

Starting from the exciter, RF need to arrive at the antenna. This is done through your feedline. Next it needs to enter through the antenna. This is accomplished by ending the feedline with a radiating resonant circuit - the antenna. Contrary to popular opinion the impedance match has very little affect on performance of the antenna. A mismatch of up to 6:1 SWR will still provide performance that compares to a 1:1 SWR.

This is not to be confused with the exciter protection circuit that reduces power output, in some cases at a 1.5:1 SWR and higher. This can be overcome with the use of an outboard tuner for those solid state exciters.

In most cases a 1:1 SWR can be achieved with the Isotrons. However, many are operating in very tight locations which may make it difficult to achieve the ideal match from the antenna. The antennas radiation will still be optimum as long as you adjust the resonant point. The resonant point can be adjusted in any location regardless of how tight the installation is. The radiation performance can easily be checked by a simple Field Strength test, either using a Field Strength meter or another local station close by.

From this point radiation is at the mercy of the environment which will determine how well your signal is received by other stations. Height enhances your performance best. So do not sacrifice height if you have a choice. The Isotrons are designed to mount high with a light mast so you can take advantage of this feature.

WARRANTY

Bilal Company warrants this equipment against defects in material and workmanship for a period of one year from the date of purchase.

This warranty is limited to replacing or repairing the defective parts and is not valid if the equipment has been tampered with, misused or damaged.

NOTE: Do not ship to the factory without prior authorization.

First write or describe the difficulty. Many times we can diagnose and correct problems by mail.



160 Meter Antenna

Specifications

Size (H x W x D)	9'5" x 16" x 15"
Bandwidth	100 KHz *
Impedance	50 - 75 ohms
Freq. Range	1.8 - 2.0 Mhz
Power Input	1000 watts PEP**
Wind Load (sq. feet)	1.69
Wind Rating	85
Pattern	Omni
Weight	7 lbs.

PRICE: \$173.95

* Bandwidth is within 2:1 SWR. May vary with environment.
** 300 watt CW (AM, FM, RTTY, etc.)

[Click Here for Order Page](#)

[Back to Isotron Price List & Specifications Page](#)
[Back to Isotron Main Page](#)